



Thermoplastic Hoses

THERMOPLASTIC HOSES FOR HIGH AND ULTRA-HIGH PRESSURE

Thermoplastic hoses specially developed for fluid transmission under high and ultra-high pressure conditions.

They are easy to handle and install and are used where maximum safety is required.

Thermoplastic hoses provide excellent mechanical and chemical resistance, with durability far superior to rubber hoses.

All fittings marketed by GEPEF are manufactured in-house.

If the required fitting is not listed in this catalog, please contact our technical department.

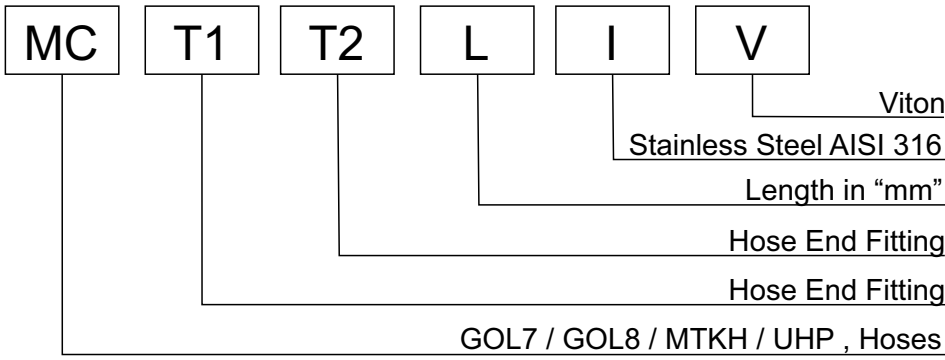
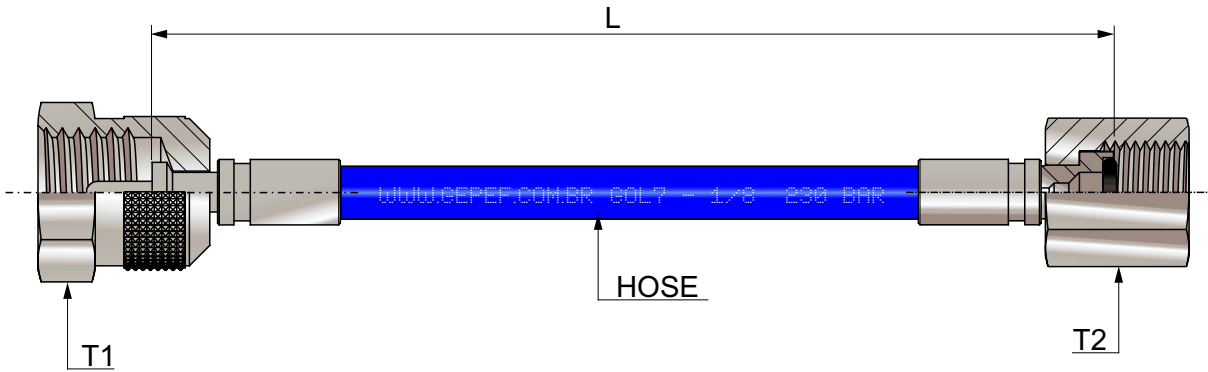

Coding example:

GOL7 1/4 P M16x2 - E G1/4 BSP x 1.000mm (Thermoplastic hose GOL7 1/4 with fittings P M16x2 and E G1/4 BSP, length 1000 mm).

For AISI 316 stainless steel, add the letter I at the end of the code.

For Viton (FKM) or EPDM seals, add the letter V or E at the end of the code.

If another type of hose or fitting not listed in this catalog is required, please contact our technical department.



Type	Dash Size	DN	Inside Diameter I.D	Outside Diameter O.D	Working Pressure (bar / PSI)	Burst Pressure (bar / PSI)	Bend Radius	Weight g/m
GOL7 - 1/8	-2	3	3,5 mm	8,5 mm	230 / 3340	920 / 13340	12 mm	57
GOL7 - 3/16	-3	5	4,8 mm	10,0 mm	210 / 3045	840 / 12180	30 mm	73
GOL7 - 1/4	-4	6	6,4 mm	11,8 mm	200 / 2900	800 / 11600	35 mm	90
GOL7 - 3/8	-6	10	9,7 mm	16,0 mm	175 / 2535	700 / 10150	55 mm	155
GOL7 - 1/2	-8	12	13,0 mm	20,3 mm	140 / 2030	560 / 8120	75 mm	219
GOL7 - 5/8	-10	16	16,0 mm	23,5 mm	105 / 1520	420 / 6090	120 mm	277
GOL7 - 3/4	-12	19	19,2 mm	26,5 mm	90 / 1305	360 / 5220	145 mm	330
GOL7 - 1	-16	25	25,6 mm	33,6 mm	70 / 1015	280 / 4060	200 mm	403

Construction

Inner tube in thermoplastic polyester, polyester fiber reinforcement, and UV-resistant polyurethane outer cover.

UV-resistant polyurethane outer cover. Pin-pricked for use with air and compatible gases.

Applications

The GOL 7 series hoses were designed for medium-pressure hydraulic applications.

Temperature Range

-54°C to +100°C / (-65°F to +212°F) - Maximum for air and water-based fluids: +70°C (158°F)

Working Pressure

Safety Factor: 1:4

Vacuum

0.93 bar ; 700 mm Hg

Standards

SAE J517-100 R7 and ISO 3949



Type	Dash Size	DN	Inside Diameter I.D	Outside Diameter O.D	Working Pressure (bar / PSI)	Burst Pressure (bar / PSI)	Bend Radius	Weight g/m
GOL8 - 1/8	-2	3	3,5 mm	7,1 mm	420 / 6090	1680 / 24360	30 mm	37
GOL8 - 1/8	-2	3	3,5 mm	8,5 mm	700 / 10152	2100 / 30456	30 mm	55
GOL8 - 3/16	-3	5	4,8 mm	10,0 mm	350 / 5075	1400 / 20300	35 mm	72
GOL8 - 1/4	-4	6	6,4 mm	11,8 mm	350 / 5075	1400 / 20300	50 mm	85
GOL8 - 3/8	-6	10	9,7 mm	16,0 mm	280 / 4060	1120 / 16240	80 mm	146
GOL8 - 1/2	-8	12	13,0 mm	20,3 mm	245 / 3550	980 / 14210	70 mm	225
GOL8 - 5/8	-10	16	16,0 mm	23,5 mm	195 / 2830	780 / 11300	125 mm	265
GOL8 - 3/4	-12	19	19,2 mm	26,5 mm	165 / 2390	660 / 9570	150 mm	352
GOL8 - 1	-16	25	25,6 mm	34,7 mm	145 / 2100	580 / 8410	200 mm	505

Construction

Inner tube in thermoplastic polyester, reinforcement with high-tenacity textile fibers, and UV-resistant polyurethane outer cover.
 UV-resistant polyurethane outer cover. Pin-pricked for use with air and compatible gases.

Applications

The GOL 8 series hoses were designed for medium-pressure hydraulic applications.

Temperature Range

-40°C to +100°C / (-40°F to +212°F) - Maximum for air and water-based fluids: +70°C (158°F)

Working Pressure

Safety Factor: 1:4

Vacuum

0.93 bar ; 700 mm Hg

Standards

SAE J517-100 R8 and ISO 3949.



Type	Dash Size	DN	Inside Diameter I.D	Outside Diameter O.D	Working Pressure (bar / PSI)	Burst Pressure (bar / PSI)	Bend Radius	Weight g/m
MTKH - 1/4	-4	6	6,4 mm	14,5 mm	700 / 10150	280 / 40600	40 mm	260
MTKH - 3/8	-6	10	9,5 mm	18,0 mm	425 / 6162	1700 / 24650	60 mm	344
MTKH - 1/2	-8	12	13,0 mm	22,0 mm	375 / 5430	1500 / 21750	75 mm	460
MTKH - 3/4	-12	19	19,2 mm	28,2 mm	225 / 3260	900 / 13050	150 mm	659

Construction

Inner tube in thermoplastic polyester, reinforced with high-strength braided aramid fiber.
 UV-resistant polyurethane outer cover. Pin-pricked for use with air and compatible gases.

Applications

The MTKH series hoses were developed for high-pressure hydraulic and pneumatic applications.

Temperature Range

-40°C to +100°C (-40°F to +212°F) — Maximum working temperature with air, water, and water-based fluids: +70°C (158°F).

Working Pressure

Safety Factor: 1:4

Vacuum

0.93 bar ; 700 mm Hg

Standards

NFPA 1936 E M SHA



Type	Dash Size	DN	Inside Diameter I.D	Outside Diameter O.D	Working Pressure (bar / PSI)	Burst Pressure (bar / PSI)	Bend Radius	Weight g/m
UHP - 1/8	-2	3	3,5 mm	11,2 mm	1120 / 16240	2800 / 40600	25 mm	180
UHP - 3/16	-3	5	4,8 mm	11,3 mm	800 / 11600	2000 / 29000	30 mm	167
UHP - 1/4	-4	6	6,4 mm	14,5 mm	1120 / 16240	2800 / 40600	40 mm	253
UHP - 5/16	-5	8	8 mm	16 mm	1000 / 14500	2500 / 36250	50 mm	292
UHP - 3/8	-6	10	9,5 mm	18,8 mm	1120 / 16240	2800 / 40600	90 mm	389
UHP - 1/2	-8	12	13 mm	25,2 mm	1000 / 14500	2500 / 36250	150 mm	516

Construction

Inner tube in thermoplastic polyester, reinforced with aramid fiber and high-strength steel braid.

Outer cover in abrasion-resistant and UV-resistant polyurethane.

Applications

The UHP hose series was developed for high-pressure water cleaning and waterjet cutting applications.

Temperature Range

-40°C to +55°C (-40°F to +131°F) — Maximum working temperature with air, water, and water-containing fluids: +70°C (158°F).

Working Pressure

Safety Factor 1:2.5

Technical Description	End of Fitting Type	Thread T	S	D
With pin to open and close the pressure test point valve	P	M16x2	19	
		M16x1,5	19	
		S12,65x1,5	5/8"	

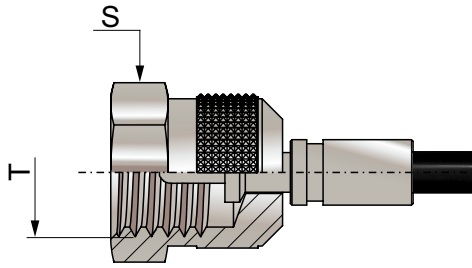

Technical Description	End of Fitting Type	Thread T	S	D
With pin to open and close the pressure test point valve	P 90°	M16x2	19	
		M16x1,5	19	
		S12,65x1,5	5/8"	

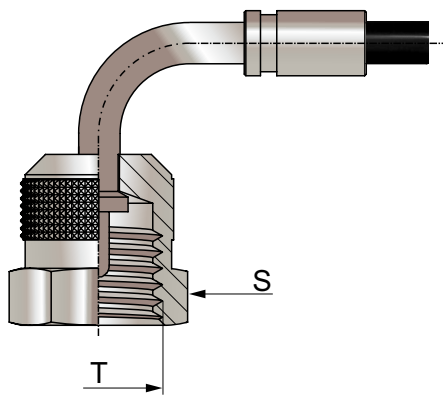

Technical Description	End of Fitting Type	Thread T	S	D
Straight Stub End DIN 2353	D			4
				6
				8
				10
				12
				1/4

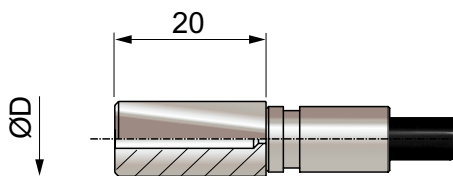

Technical Description	End of Fitting Type	Thread T	S	D
Straight Stub End DIN 2353	D 90°			4
				6
				8
				10
				12
				1/4

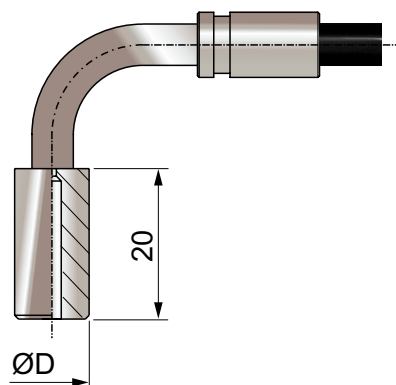

Technical Description	End of Fitting Type	Thread T	S	D
Swivel female for pressure gauges (EN 837-1)	E	G1/4 BSP	17	
		G1/2 BSP	27	
		M20x1,5	24	
		M14x1,5	17	

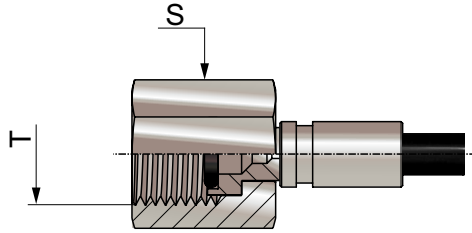

Technical Description	End of Fitting Type	Thread T	S	D
Swivel female for pressure gauges (EN 837-1)	E 90°	G1/4 BSP	17	
		G1/2 BSP	27	
		M20x1,5	24	
		M14x1,5	17	

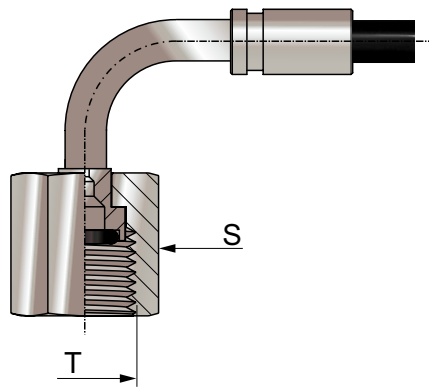

Technical Description	End of Fitting Type	Thread T	S	D
Swivel female / DKO 24° DIN 2353	F	M8x1	10	4LL
		M10x1	14	5L
		M12x1,5	14	6L
		M14x1,5	17	8L
		M16x1,5	19	10L
		M18x1,5	22	12L
		M14x1,5	17	6S
		M16x1,5	19	8S
		M18x1,5	22	10S
M20x1,5	24	12S		

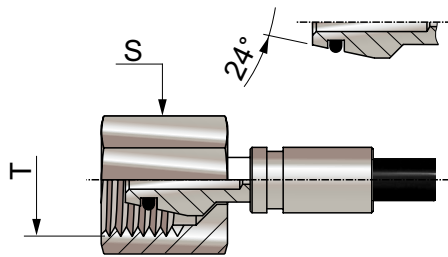

Technical Description	End of Fitting Type	Thread T	S	D
Swivel female / DKO 24° DIN 2353	F 90°	M8x1	10	4LL
		M10x1	14	5L
		M12x1,5	14	6L
		M14x1,5	17	8L
		M16x1,5	19	10L
		M18x1,5	22	12L
		M14x1,5	17	6S
		M16x1,5	19	8S
		M18x1,5	22	10S
M20x1,5	24	12S		

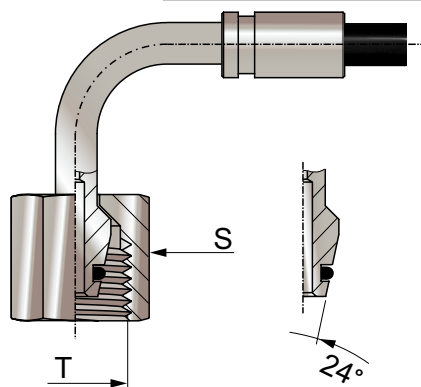

Technical Description	End of Fitting Type	Thread T	S	D
Swivel female beaded DKO 24° DIN 2353	G	M8x1	10	4LL
		M10x1	14	5L
		M12x1,5	14	6L
		M14x1,5	17	8L
		M16x1,5	19	10L
		M18x1,5	22	12L
		M14x1,5	17	6S
		M16x1,5	19	8S
		M18x1,5	22	10S
		M20x1,5	24	12S

Technical Description	End of Fitting Type	Thread T	S	D
Swivel female beaded DKO 24° DIN 2353	G 90°	M8x1	10	4LL
		M10x1	14	5L
		M12x1,5	14	6L
		M14x1,5	17	8L
		M16x1,5	19	10L
		M18x1,5	22	12L
		M14x1,5	17	6S
		M16x1,5	19	8S
		M18x1,5	22	10S
		M20x1,5	24	12S

Technical Description	End of Fitting Type	Thread T	S	D
Fixed female NPT / BSPT ANSI / ASM E B 1.20.1 - NBR 12912	I	1/8 NPT	17	
		1/4 NPT	19	
		3/8 NPT	22	
		1/2 NPT	27	
		1/8 BSPT	17	
		1/4 BSPT	19	

Technical Description	End of Fitting Type	Thread T	S	D
Fixed female NPT / BSPT ANSI / ASM E B 1.20.1 - NBR 12912	I 90°	1/8 NPT	17	
		1/4 NPT	19	

Technical Description	End of Fitting Type	Thread T	S	D
Swivel female UNF-ORFS SAE J 1453 / ISO 8434-3	FS	9/16-18 UNF	19	
		11/16-16 UNF	22	

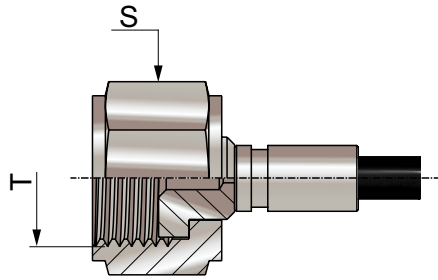

Technical Description	End of Fitting Type	Thread T	S	D
Swivel female UNF-ORFS SAE J 1453 / ISO 8434-3	FS 90°	9/16-18 UNF	19	
		11/16-16 UNF	22	

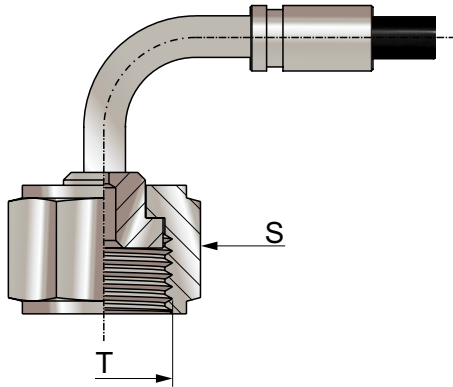

Technical Description	End of Fitting Type	Thread T	S	D
Swivel female UNF - JIC SAE J514	C	5/16-24 UNF	7/16	1/8
		7/16-20 UNF	9/16	1/4
		1/2-20 UNF	5/8	5/16
		9/16-18 UNF	3/4	3/8

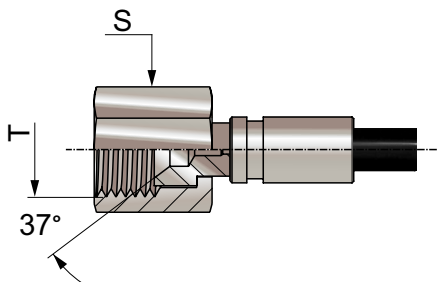

Technical Description	End of Fitting Type	Thread T	S	D
Swivel female UNF - JIC SAE J514	C 90°	5/16-24 UNF	7/16	1/8
		7/16-20 UNF	9/16	1/4
		1/2-20 UNF	5/8	5/16
		9/16-18 UNF	3/4	3/8

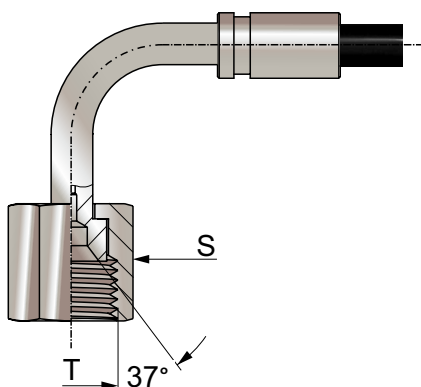

Technical Description	End of Fitting Type	Thread T	S	D
End of fitting with internal pin for pressure test point valve actuation	PE			

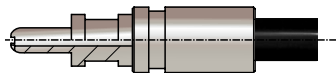

Technical Description	End of Fitting Type	Thread T	S	D
Metric swivel male	M	M8x1	3/8	

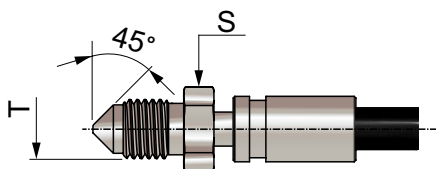

Technical Description	End of Fitting Type	Thread T	S	D
Fixed male NPT / BSPT ANSI / ASM E B 1.20.1 - NBR 12912	B	1/8 NPT	11	
		1/4 NPT	17	
		3/8 NPT	22	
		1/2 NPT	27	
		1/8 BSPT	14	
		1/4 BSPT	17	

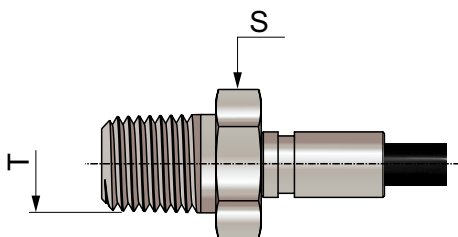

Technical Description	End of Fitting Type	Thread T	S	D
Fixed metric male 24° DIN 2353	H	M10x1	10	4
		M12x1,5	14	6
		M14x1,5	17	8
		M16x1,5	19	10

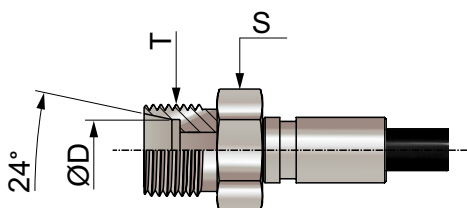

Technical Description	End of Fitting Type	Thread T	S	D
Fixed metric male / BSP ISO 1179-2 / Rosca BSP	K	M10x1	14	
		M12x1,5	17	
M14x1,5		19		
M16x1,5		22		
G1/8 BSP		14		
G1/4 BSP		19		
G1/2 BSP	27			

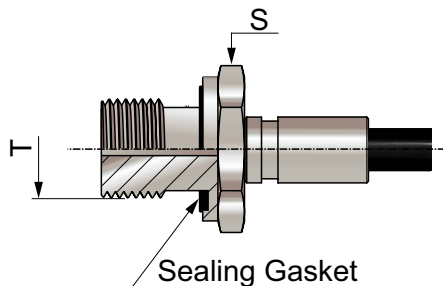

Technical Description	End of Fitting Type	Thread T	S	D
Fixed male UNF SAE J 514 (JIC)	J	5/16-24 UNF	1/2	1/8
		7/16-20 UNF	9/16	1/4
1/2-20 UNF		9/16	5/16	
9/16-18 UNF		11/16	3/8	

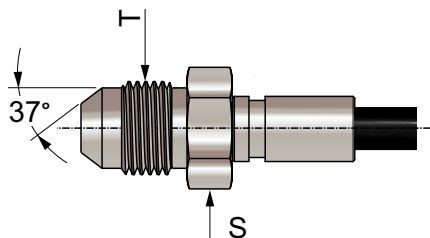

Technical Description	End of Fitting Type	Thread T	S	D
Swivel female BSP 60° Cone (ISO / DIS 8434-6)	DIS	G1/8 BSP	14	
		G1/4 BSP	17	
		G1/2 BSP	27	

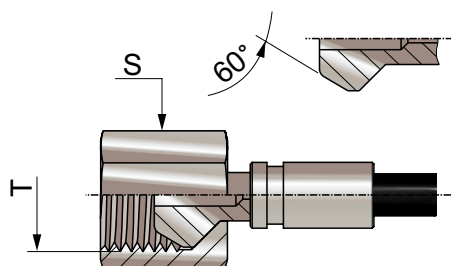

AE - Adapter for connecting two capillary test hoses

Allows the connection of M16x2 / M16x2, M16x1.5 / M16x1.5 or M16x2 / M16x1.5 hoses.

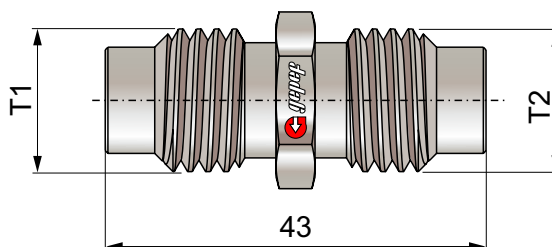

Code	T1	T2
AE-M16x2	M16x2	M16x2
AE-M16x1,5	M16x1,5	M16x1,5
AE-M16x2 - AE-M16x1,5	M16x2	M16x1,5

Coding example:

AE-M16x2 (Adapter for M16x2 Hose Splicing).

For AISI 316 stainless steel, add the letter I at the end of the code.

For Viton (FKM) or EPDM seals, add the letter V or E at the end of the code.

If you require a different adapter configuration not listed in this catalog, please contact our Technical Department.

ACMF - Conversion Adapter for “P” Type End Fittings - Refer to “Capillary Hoses”.
 Allows the conversion of an M16x2 pressure test point connection to M16x1.5 and vice versa.

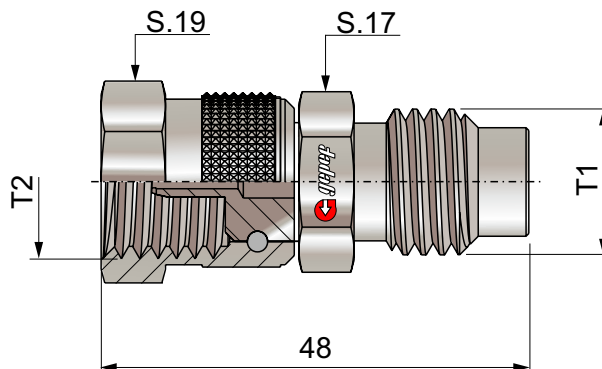

Code	T1	T2
ACMF 2/1,5	M16x2	M16x1,5
ACMF 1,5/2	M16x1,5	M16x2

Coding example:

ACMF 2/1,5 (Conversion Adapter for “P” Type End Fittings, M16x2 Male Thread, M16x1.5 Female Thread).

For AISI 316 stainless steel, add the letter I at the end of the code.

For Viton (FKM) or EPDM seals, add the letter V or E at the end of the code.

If you require a different adapter configuration not listed in this catalog, please contact our Technical Department.

INSTALLATION INSTRUCTIONS (SAE J1273 - ISO 8331)

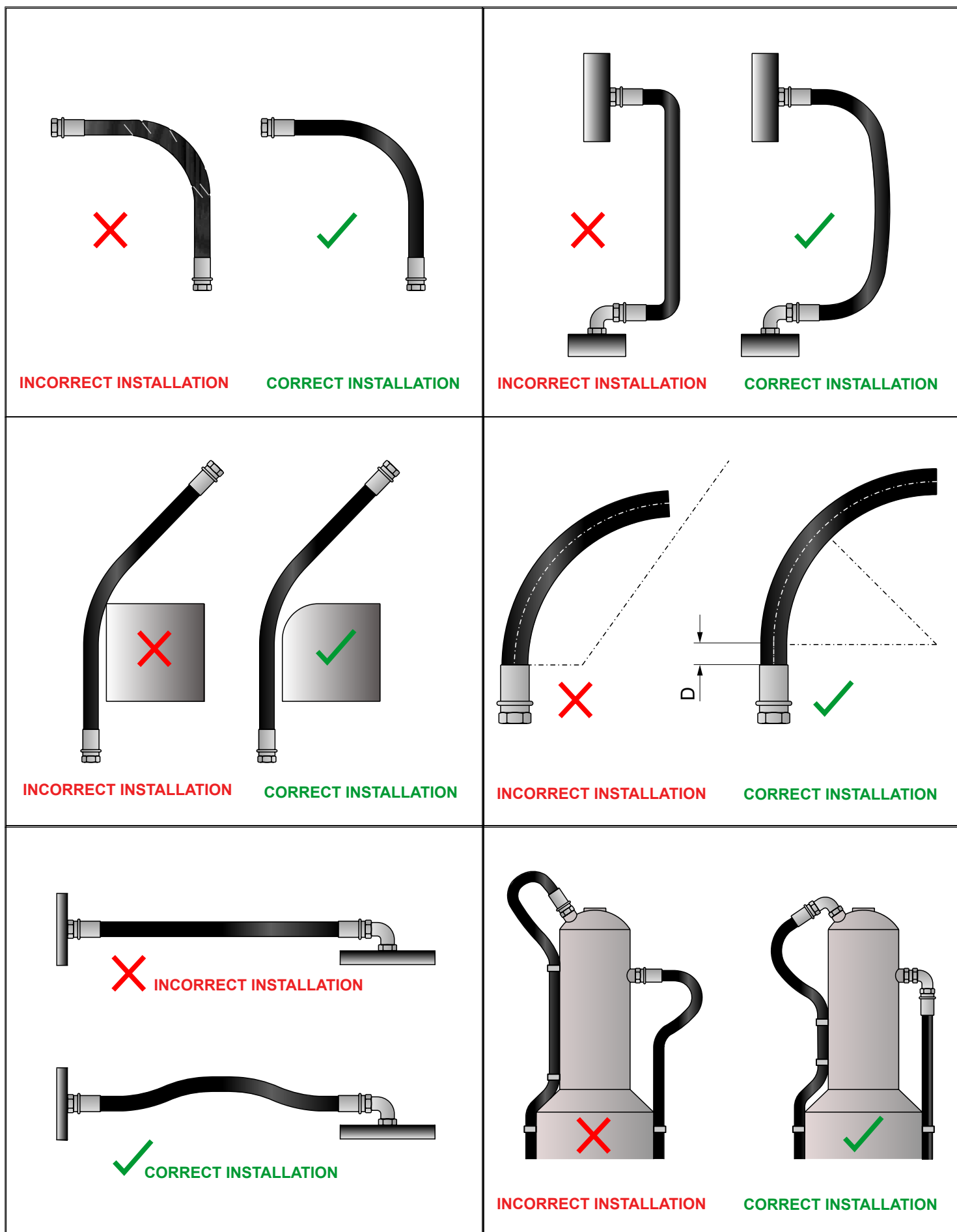

INSTALLATION INSTRUCTIONS (SAE J1273 - ISO 8331)

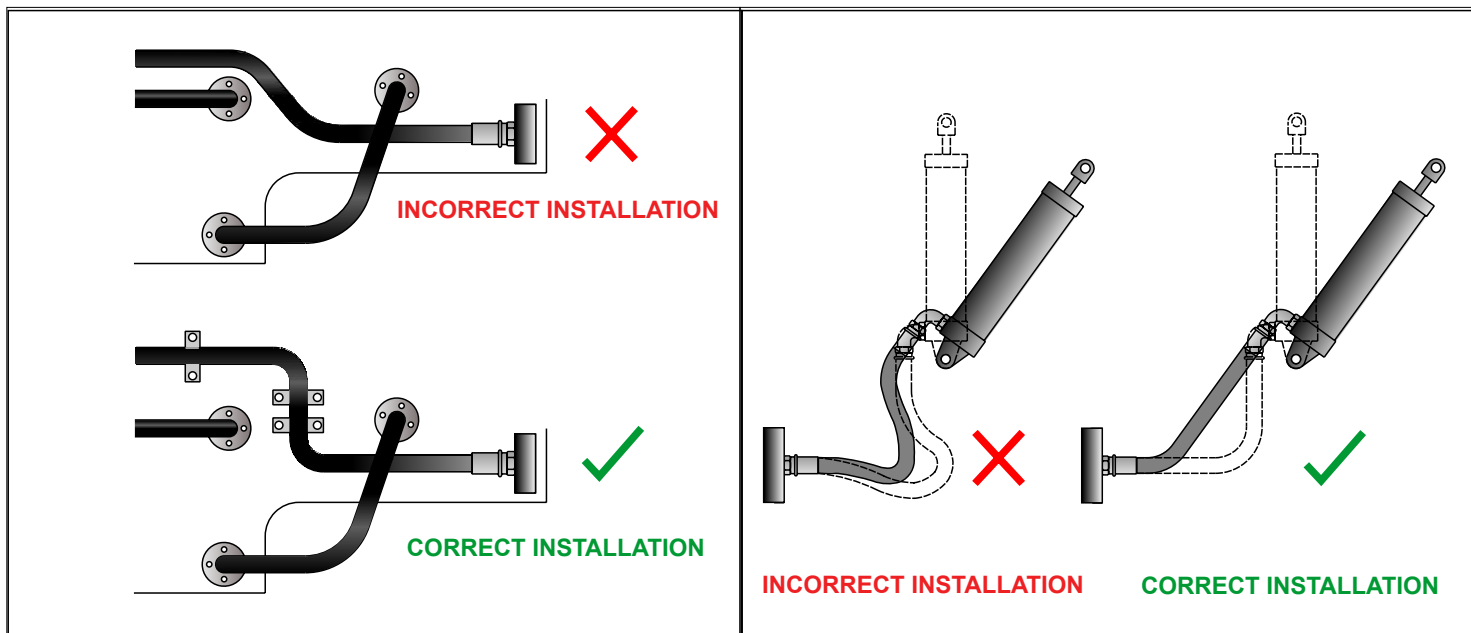



Manufacturing Facility

 + 55 15 3264-1222

 gepef@gepef.com.br

 www.gepef.com.br

 Avenida do Trabalhador, 1.680
ZIP Code 18552-100 - Boituva - SP
Brazil

Head Office & Operations Center

 Av. Antônio Ângelo Amadio 681
ZIP Code 18552-112 - Boituva - SP
Brazil

Branch Office – Belo Horizonte, MG – Brazil - Regional sales operations
for Minas Gerais and Brazil's Central-West Region

 + 55 31 3327-4459

 gepef-bh@gepef.com.br

 www.gepef.com.br

 Avenida Professor Mário Werneck, 300
(10th Floor – Room 1004 – Tower 2) – Estoril District
ZIP Code 30455-610 - Belo Horizonte - MG
Brazil